

ProSet 3400 Rivet Tool

Hydropneumatic

The lightweight ProSet® 3400 rivet tool is the heavyweight of the ProSet® family. Designed specifically to set a wide range of blind rivets, including 6.4 mm High Strength and Stainless Steel, the tool delivers 18.5 kN of pulling force with a “highest in class” force-to-weight ratio of 9.7 kN/kg.

The 3400 tool features many innovative high performance features including a patented “Quick Disconnect” nose housing and jaw case for rapid cleaning and maintenance of the front end of the tool without the need for tools. With the 3400 “Quick Disconnect” Mandrel Collection System (MCS), mandrels are safely collected and can be quickly disposed of, maintaining cleaner work areas. An air-isolation switch on the MCS prevents air flow when the MCS is disconnected and allows mandrels to be disposed of safely. The tough aluminum casing enhances the life of the tool.

A left or right 90° swivel air fitting ensures the tool can be adapted to virtually any workstation configuration, while the “on/off” switch minimises air consumption. A spring return ensures fast, reliable setting cycles. An extended 200 mm front end is also available for extra reach in special setting situations.



Requires no tools for routine maintenance and cleaning. Front end components can be serviced in minutes right on the production line, eliminating costly downtime.

Placing Capability

3.2 mm, 4.0 mm, 4.8 mm and 6.4 mm diameter rivets in all materials including stainless steel high strength structural rivets.

Technical Data

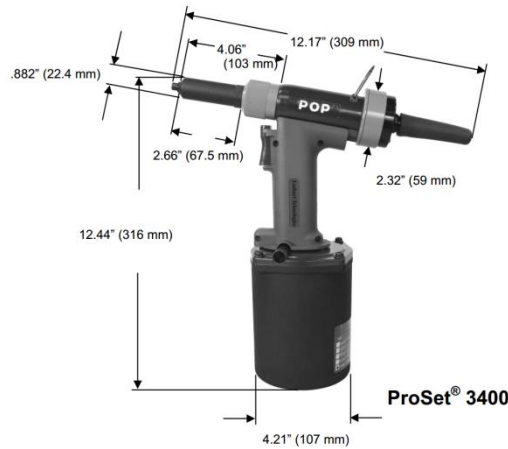

Performance

- High force-to-weight ratio
- Quick disconnect nose housing, jaw case, and mandrel collector
- Spring return for a reliable fast setting cycle

Ergonomic

- Lightweight, strong polymer construction
- Comfortable two finger, low activation force trigger
- Directionable air exhaust (MCS model)
- On/Off, left or right swivel air fitting

Safety

- Air-isolation switch during MCS removal

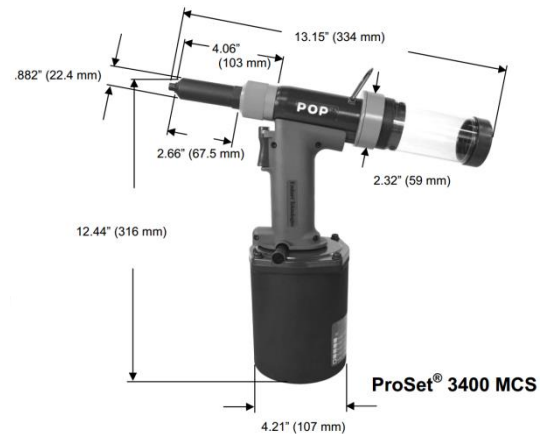

Weight	:	1.90 kg
Tool Stroke	:	26 mm
Working Pressure	:	5.0 - 6.9 bar
Pulling Force	:	18,500 N at 6.2 bar
Force / Weight Ratio	:	9.7 kN/kg
Air Consumption	:	4.86 litres / rivet

	:	2.00 kg
	:	26 mm
	:	5.0 - 6.9 bar
	:	18,500 N at 6.2 bar
	:	9.2 kN/kg
	:	80 litres / min (max)

For accessories options, contact Gripwell Sales for assistance